



350 S. St. Charles St. Jasper, In. 47546
Ph. 812.482.2932 Fax 812.634.6632

www.ridetech.com

Part # 13040298
05-14 Mopar LX Air Suspension System

Front Components:

1 13042401 Front HQ ShockWave Kit for Stock Lower Arms

Rear Components:

1 13044099 Rear CoolRide Kit

1 13040701 HQ Series Rear Shocks



350 S. St. Charles St. Jasper, In. 47546

Ph. 812.482.2932 Fax 812.634.6632

www.ridetech.com

Part # 13042401

Mopar LX Platform Front Shockwave – HQ Series
05-08 Magnum / 05-Up 300C / 06-Up Charger / 08-Up Challenger

Shockwave:

2	24190198	1000 Master Series double convoluted bellow assembly
2	24559999	5" stroke shock w/ threaded bottom – HQ Series
2	90002357	Aluminum Reducer Puck
2	90009988	2" Stud top (Stud top base not needed)
2	90001668	(SKW076) Aluminum lower shock mount
2	90009980	(A953) Lower Shockwave steel bracket
2	70008913	Locking Ring

Components:

4	90002229	Steel washer for rubber mount (2.375" O.D.)
2	90001974	Upper rubber isolator
2	90001973	Lower rubber isolator (T-shaped)
2	90001971	Aluminum upper ShockWave plate
2	90002448	Wide Lower Shockwave steel bracket
2	31954201	1/4" x 1/4" swivel elbows

Hardware:

2	99562003	9/16" SAE Nylok jam nut	Stud top to upper mount
2	99561006	9/16" x 3 1/2" SAE bolt	Lower bracket to lower arm
2	99562005	9/16" SAE Nylok nut	Lower bracket to lower arm
6	99371006	3/8" x 1 1/2" USS bolt	Aluminum plate to body
6	99372001	3/8" USS Nylok nut	Aluminum plate to body
12	99373003	3/8" SAE washer	Aluminum plate to body
2	99501029	1/2"-13 x 6 1/2" Bolt	Lower Shock Mount to Shock
2	99503002	1/2" Split Lock Washer	Lower Shock Mount to Shock

Mopar LX Front ShockWave Assembly

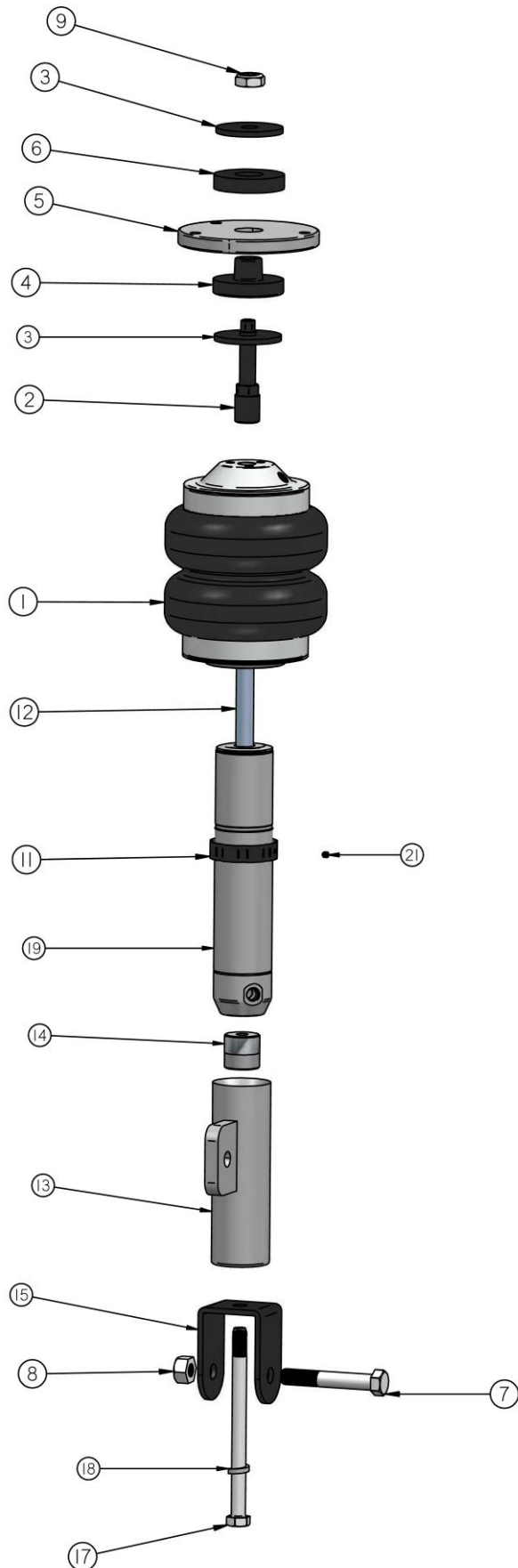

Item Number	Description	Qty.
1	255 (6.5") bellow assembly 24190199	2
2	Short stud top 90009988	2
3	Washer for Rubber Mount 90002229	4
4	Lower Rubber Isolator(T- shaped)90001973	2
5	Upper mounting plate 90001971	2
6	Upper Rubber Isolator 90001974	2
7	9/16" X 3 1/2" Bolt	2
8	9/16" SAE Nylok nut	2
9	9/16" SAE jam Nylok nut	2
11	Locking Ring 70008913	2
13	Bottom lower billet mount 90001668	2
14	Aluminum Reducer Puck 90002357	2
15	Lower Steel Shockwave Bracket-90009980	2
17	1/2"-13 x 6 1/2" USS bolt	2
18	1/2" Lock Washer	2
19	5.2" Shock w/ universal bottom - 24559999	2
21	Set Screw	2

SHOCKwave®

by Air Ride Technologies

Installation Instructions

1. Raise the vehicle to a safe and comfortable working height with the suspension hanging freely.
2. Remove the factory struts and upper mounts; refer to the service manual for proper disassembly procedures.
3. Due to 2 possible lower mount options on this platform, included in the kit are 2 different widths of lower mounts.
4. Determine the width of Lower Mount required for your application by test fitting the supplied mounts. Refer to the diagram below for assembly and clocking of the lower bracket.

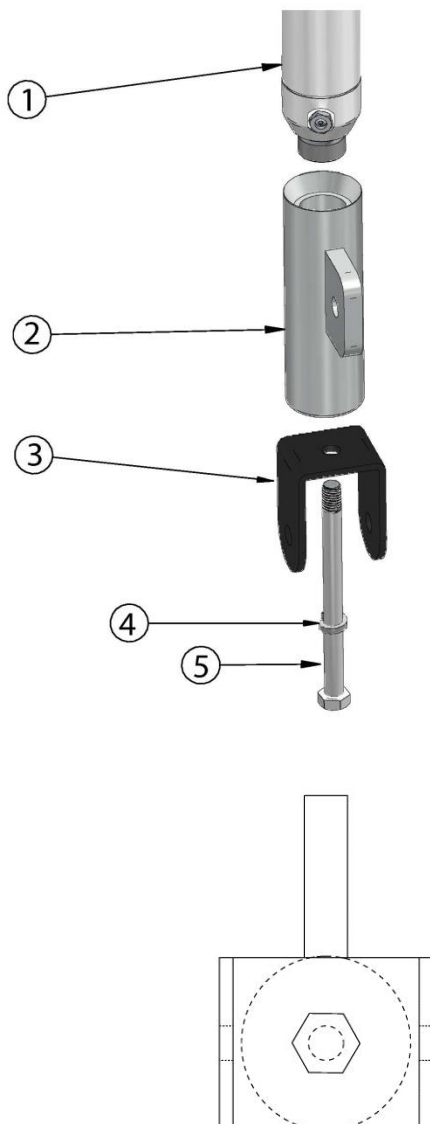

1. Shock Assembly
2. Lower Shock Adapter
3. Lower Shock Mount
4. 1/2" Split Lock washer
5. 1/2" x 6 1/2" Hex Bolt

Assembly

1. Slide the Shock Adapter onto the Shock Assembly.
2. Install the Split Lock washer onto the 1/2" x 6 1/2" Bolt.
3. Apply Red Loctite onto the threads of the bolt.
4. Insert the Bolt through the Lower Shock Mount and into the bottom hole of the Shock Adapter.
5. Thread the bolt into the Shock. **The Lower Shock Mount has to be clocked so that the Shock Mount Tabs run parallel with the Sway Bar Mount on the Adapter.** The diagram here shows correct clocking of the bracket.
6. With the bracket clocked correctly, tighten the 1/2" Bolt.

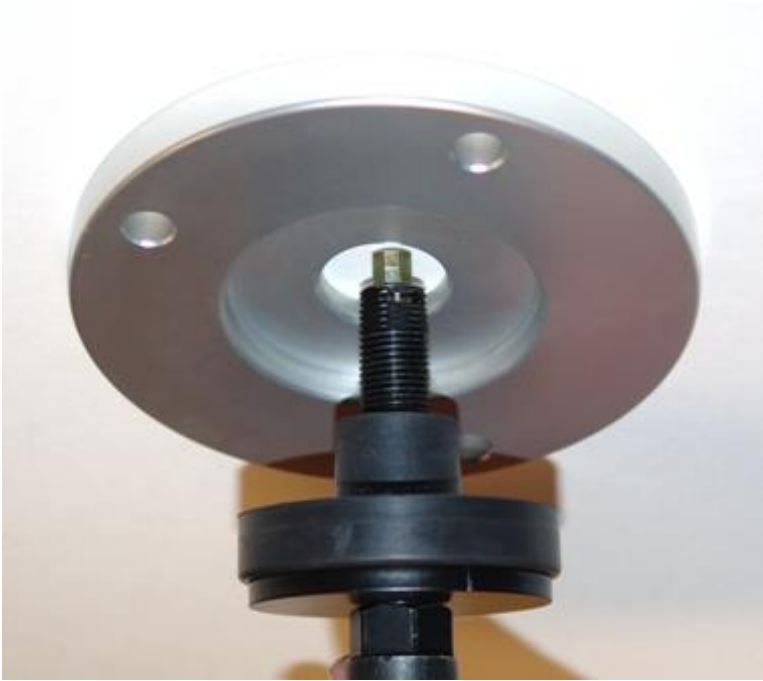

5. Bolt the aluminum upper plate to the car in place of the factory rubber mount using the 3/8" x 1 1/4" bolts, flat washer and Nylok nuts.

Note: The recessed side of the plate must face down.

6. Place one of the 2.375" steel washers over the threaded stud. Then slide the T shaped rubber bushing over the stud. Place the Shockwave into the coil spring pocket with the stud protruding through the hole in the aluminum plate.



7. From the engine bay, place the other rubber bushing over the stud, then another steel plate. Secure the assembly with a 9/16" SAE Nylok Jam nut. **Note:** Some cars may have a plastic cover in the engine bay that may need to be clearance for the adjustment knob.

8. Bolt the bottom of the Shockwave assembly to the lower arm using a 9/16" x 3 1/2" bolt and Nylok nut.

9. Attach sway bar to Shockwave using the factory hardware.



10. Apply thread sealant to an elbow air fitting and screw it into the top of the Shockwave.

11. Route the airline. Allow slack for suspension movement.

12. Check air spring clearance through full suspension travel. **Allowing the Shockwave to rub on anything will result in air spring failure and in not a warrantable situation.**

13. Ride height on this car is approximately 2" lower than factory. On most vehicle this will occur around 100psi, but will vary per vehicle.

The care and feeding of your new ShockWaves

1. Although the ShockWave has an internal bumpstop, **DO NOT DRIVE THE VEHICLE DEFLATED RESTING ON THIS BUMPSTOP. DAMAGE WILL RESULT.** The internal bumpstop will be damaged, the shock bushings will be damaged, and the vehicle shock mounting points may be damaged to the point of failure. **This is a non warrantable situation.**
2. Do not drive the vehicle overinflated or "topped out". Over a period of time the shock valving will be damaged, possibly to the point of failure. **This is a non warrantable situation!** If you need to raise your vehicle higher than the ShockWave allows, you will need a longer unit.
3. The ShockWave is designed to give a great ride quality and to raise and lower the vehicle. **IT IS NOT MADE TO HOP OR JUMP!** If you want to hop or jump, hydraulics are a better choice. This abuse will result in bent piston rods, broken shock mounts, and destroyed bushings. **This is a non warrantable situation.**
4. Do not let the ShockWave bellows rub on anything. Failure will result. **This is a non warrantable situation.**
5. The ShockWave product has been field tested on numerous vehicles as well as subjected to many different stress tests to ensure that there are no leakage or durability problems. Failures have been nearly nonexistent unless abused as described above. If the Shockwave units are installed properly and are not abused, they will last many, many years. **ShockWave units that are returned with broken mounts, bent piston rods, destroyed bumpstops or bushings, or abrasions on the bellows will not be warrantied.**



350 S. St. Charles St. Jasper, In. 47546
Ph. 812.482.2932 Fax 812.634.6632

www.ridetech.com

Part # 13044099
Mopar LX Rear CoolRide Kit

Components:

2	90006781	267c air spring
1	90000713	Driver side upper air spring mount
1	90000714	Passenger side upper air spring mount
2	90000715	Lower air spring plate

Hardware:

10	99372002	3/8" USS Nylok nut	Air spring mounts
4	99371003	3/8" x 1" USS bolt	Upper air spring mount to car
4	99371017	3/8" x 3/4" button head	Air spring to lower plate/ lower plate to arm
2	99373005	3/8" lock washer	Air spring to lower plate
16	99373003	3/8" SAE flat washer	Air spring mounts
2	99431001	7/16" x 1" USS bolt	Lower plate to arm
2	99433002	7/16" SAE flat washer	Lower plate to arm
2	99433003	7/16" lock washer	Lower plate to arm

COOLRiDE[®]

by Air Ride Technologies

Installation Instructions

1. Raise the vehicle to a safe and comfortable working height with the suspension hanging freely.
2. Remove the factory shock absorbers and coil spring. Refer to a factory service manual for proper disassembly procedures.

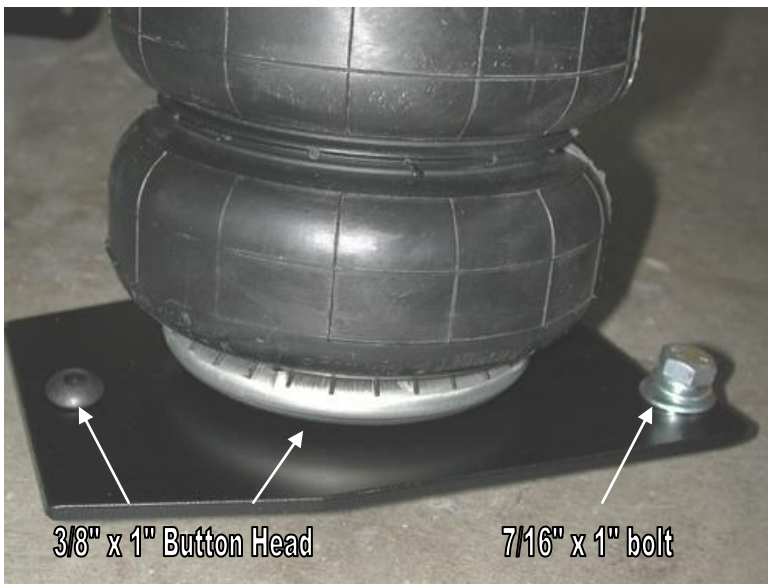

3. Bolt the air spring to the lower plate use the 3/8" x 3/4" button head bolt, lock washer and flat washer.

4. Apply thread sealant to an elbow air fitting and screw it into the top of the air spring.

5. Fasten the upper mount to the air spring using two 3/8" Nylok nuts and flat washers.



6. The hole being tapped in the picture will be used to bolt the lower air spring plate; a 7/16" x 1" bolt, flat washer and lock washer will be used. A 7/16" USS tap will be needed.

7. The inside hole on the plate will be fastened with a 3/8" x 1" button head. **The button head must be used**, a hex bolt could rub the air spring and cause failure. There is an existing hole in the lower arm.



8. Hold the air spring assembly up to the coil spring pocket. Using a camp to hold the bracket in place; center punch and drill the two mounting holes.

9. Secure the assembly with two 3/8" x 1" bolts, Nylok nuts and flat washers.

Note: The air line must be routed at this time.



14. Double-check air spring clearance through full suspension travel. **Allowing the air spring to rub will cause air spring failure and is not a warrantable situation.**

15. Ride height on this air spring is 5" tall. This will be achieved at around 100psi but will vary to driver preference & vehicle weight.



350 S. St. Charles St. Jasper, In. 47546
Ph. 812.482.2932 Fax 812.634.6632

www.ridetech.com

Part # 13040701
Mopar LX Rear HQ Series Shock Kit

Components:

4	90002443	Aluminum spacers for lower bearing (USES OEM HARDWARE)
4	90002043	Aluminum T-bushing for upper bearing
2	90001621	Upper shock bracket
2	90002230	Upper shock bracket washer
2	90001976	Bushing sleeve (Pressed into factory bushing)
2	TQ Series adjustable shocks (<i>includes the following</i>)	
2	24179999	7" stroke Master Series single adjustable shock
2	90002026	4" Master Series eyelet (w/ knob)
4	90001994	.625" I.D. bearing (installed into shock body)
4	90001995	Bearing snap ring

Hardware:

2	99501003	1/2" x 2 1/2" USS bolt	Shock to upper bracket
4	99502001	1/2" USS Nylok nut	Shock to upper bracket & OEM Mount
2	99501004	1/2" x 3" USS bolt	Shock mount to OEM Mount
2	99503004	1/2" Fender washer	Shock bracket to factory mount

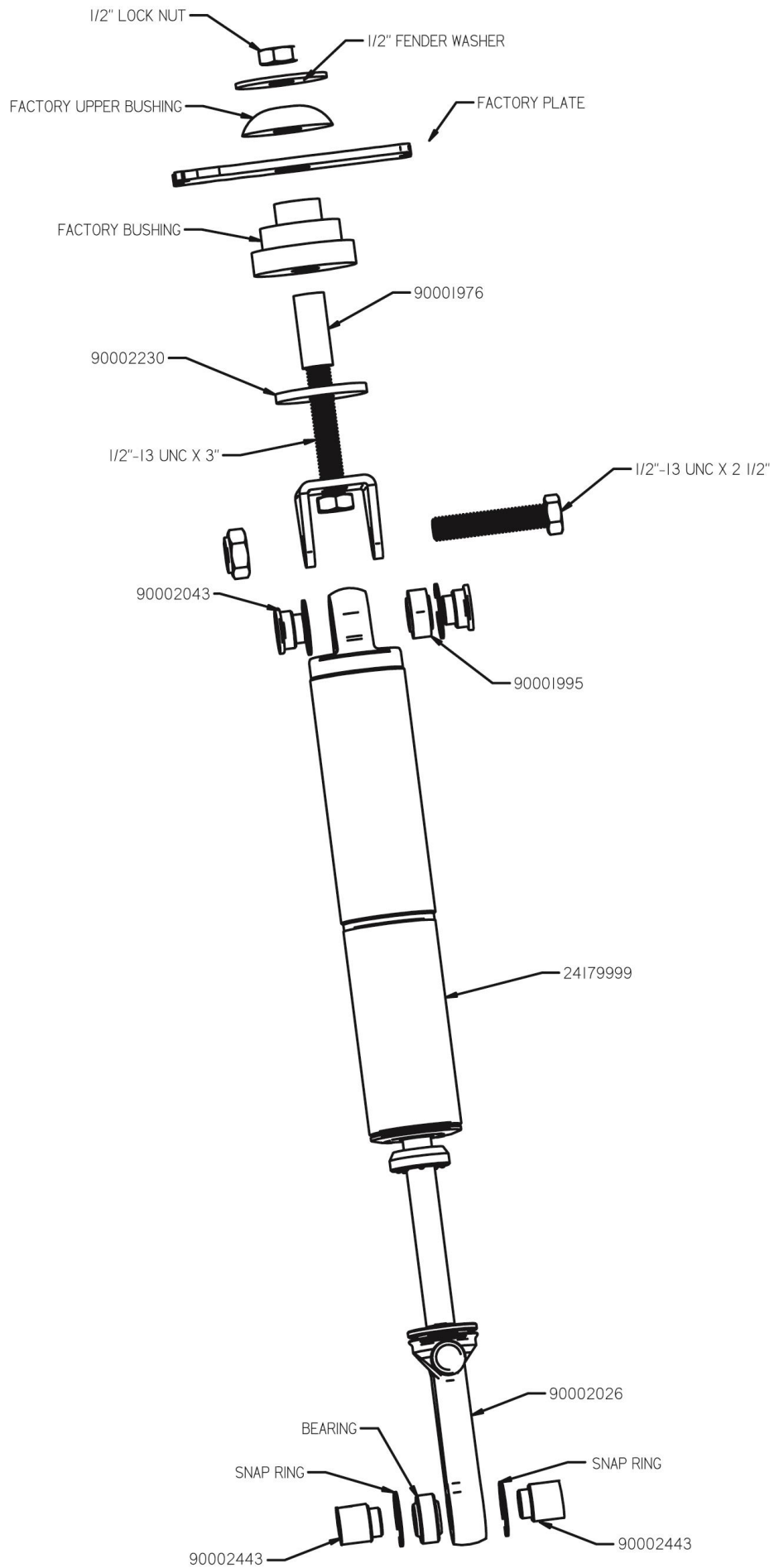

COOLRiDE[®]

by Air Ride Technologies

Installation Instructions

1. Raise the vehicle to a safe and comfortable working height with the suspension hanging freely.
2. Remove the factory shock absorbers and coil spring. Refer to a factory service manual for proper disassembly procedures.



3. Press the 1.6" bushing sleeve into the oem rubber shock mount.

4. Bolt the upper shock mount to rubber oem mount using the 1/2" x 3" bolt, Nylok nut and fender washer. The 2" plate must be installed between the bracket and the rubber bushing.

5. Using a 1/2" x 2 1/2" bolt and Nylok nut, fasten the top of the shock to the upper mount. **The shock body should be mounted on top.** One aluminum T-bushing must be installed on each side of the bearing.



6. Bolt the eyelet to the lower control arm using the OEM Bolt & nut. The thicker aluminum spacer must be installed on each side of the bearing.